



Electronic Temperature Transmitter ETS 7200

Description:

The ETS 7200 is an electronic temperature transmitter which, because of its compact design, is particularly suited to measuring temperature in hydraulic applications in the industrial and mobile sectors. Based on a silicon semiconductor device and corresponding evaluation electronics, the temperature sensor is designed to measure temperatures in the range -13 °F..+212 °F.

The sensor has various analog output signals as standard, e.g. 4 .. 20 mA or 0 ... 10V to enable integration into modern control systems through an M12x1 connector.

The pressure resistance up to 8700 bar and excellent EMC characteristics make the ETS 7200 ideal for use in harsh conditions.

Special features:

- Accuracy $\leq \pm 2$ % FS
- Ideal for OEM applications
- Very compact design
- Excellent EMC characteristics
- Long-term stability
- Standard protection class IP 67

Technical data:

Input data	
Measuring principle	Silicon semiconductor device
Measuring range	-13..+212 °F (-25..+100 °C)
Probe length	10 mm
Probe diameter	6.7 mm
Pressure resistance	8700 psi
Overload pressure	13050 psi
Mechanical connection	G1/4 A DIN 3852
Torque value	15lb-ft (20 Nm)
Parts in contact with medium	Mech. conn.: Stainless steel Seal: FPM
Output data	
Output signal, permitted load resistance	4 .. 20 mA, 2 conductor $R_{Lmax} = (U_B - 8 V) / 20 \text{ mA}$ [kΩ] 0 .. 10 V, 3 conductor $R_{Lmin} = 2 \text{ kΩ}$
Accuracy (at room temperature)	$\leq \pm 1.0$ % FS typ. $\leq \pm 2.0$ % FS max.
Temperature drift (environment)	$\leq \pm 0.012$ % FS / °F
Rise time to DIN EN 60751	t_{50} : 4 s t_{90} : 8 s
Environmental conditions	
Ambient temperature range	-13..176 °F
Storage temperature range	-40..212 °F
Fluid temperature range ¹⁾	-40..+212 °F / -13..+212 °F
CE mark	EN 61000-6-1 / 2 / 3 / 4
us mark ²⁾	Certificate No. E318391
Vibration resistance to DIN EN 60068-2-6 at 10 .. 500 Hz	≤ 20 g
Protection class to IEC 60529	IP 67
Other data	
Supply voltage	8 .. 30 V DC 2 conductor 12 .. 30 V DC 3 conductor
for use acc. to UL spec.	- limited energy - according to 9.3 UL 61010; Class 2; UL 1310/1585; LPS UL 60950
Residual ripple of supply voltage	≤ 5 %
Current consumption	≤ 25 mA
Weight	~ 50 g

Note: Reverse polarity protection of the supply voltage, excess voltage, override and short circuit protection are provided.

FS (Full Scale) = relative to complete measuring range

¹⁾-13 °F with FPM seal, -40 °F on request

²⁾ Environmental conditions according to 1.4.2 UL 61010-1; C22.2 No 61010-1

Model code:

ETS 7 2 4 6 - X - 010 - 000

Mechanical connection

4 = G1/4 A DIN 3852 (male)

Electrical connection

6 = Male M12x1, 4 pole
(connector not supplied)

Signal

A = 4 .. 20 mA, 2 conductor

B = 0 .. 10 V, 3 conductor

Probe length

010 = 10 mm

Modification number

000 = Standard

Accessories:

Appropriate accessories, such as electrical connectors can be found in the Accessories brochure.

Pin connections:

M12x1

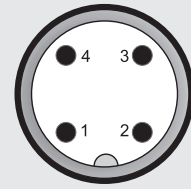

Pin	ETS 7246-A	ETS 7246-B
1	Signal+	+U _B
2	n.c.	n.c.
3	Signal-	0 V
4	n.c.	Signal

Dimensions:

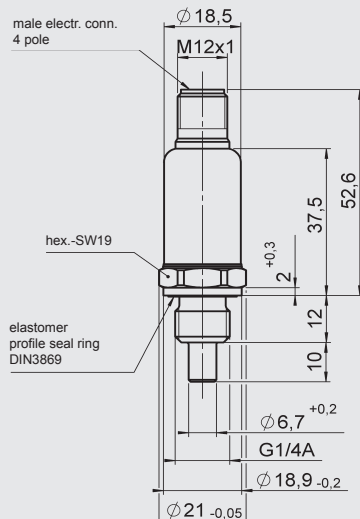

Note:

The information in this brochure relates to the operating conditions and applications described.

For applications or operating conditions not described, please contact the relevant technical department.

Subject to technical modifications.

HYDAC ELECTRONICS

90 Southland Dr. Bethlehem, PA 18017

Telephone: +1 (610) 266-0100

E-mail: electronics@hydacusa.com

Website: www.hydac-na.com